

The Golden Splice: Beginning a Global Digital Phone Network

December 1992

John Landwehr
Northwestern University
email: jland@nwu.edu

On Monday November 16, 1992 the nation's first multi-services all-digital telephone network was launched. The phrase "Golden Splice" was coined on that day to recall the first transcontinental rail system in 1869, which was completed with the pounding of the infamous golden spike. But unlike the rail system, the telephone system's "tracks" have been in place for years. With today's technology, the information sent across the wires is changing. The transition is from analog signals to digital, using technology called ISDN. This paper will discuss the beginnings of ISDN and how the world will benefit by communicating in binary numbers.

What is ISDN?

ISDN, which stands for integrated services digital network, is a system of digitizing phone networks which has been in the works for over a decade. This system allows audio, video, and text data to be transmitted simultaneously across the world using end-to-end digital connectivity.

The original telephone system used analog signals to transmit a signal across telephone wires. The voice was carried by modulating an electric current with a waveform from a microphone. The receiving end would then vibrate a speaker coil for the sound to travel back to the ear through the air. Most telephones today still use this method.

Computers, however, are digital machines. All information stored on them is represented by a bit, representing a zero or a one. Multiple bits are used to represent characters, which then can represent words, numbers, programs, etc.

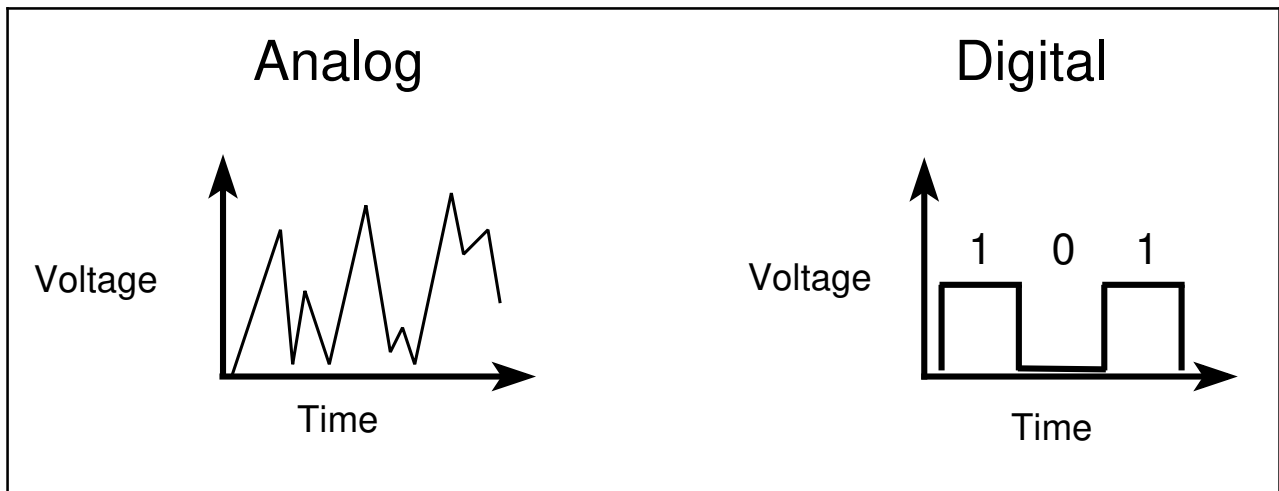

Figure 1 analog versus digital communications

The analog signals are just varying voltages sent across the wires over time. The digital signals are represented as a positive or negative voltage changing over time.

The modem was certainly a big breakthrough in computer technology. It allowed computers to communicate with each other by converting their digital communications into an analog format to travel through the public phone network. But there is a limit to the amount of information that a common analog telephone line can hold. Currently, it is about 56 kbps.

ISDN allows multiple digital channels to be operated simultaneously through the same regular phone jack in a home or office. The change comes about when the telephone company's switches are upgraded to handle digital calls. Therefore, the same wiring can be used, but a different signal is transmitted across the line.

Previously, it was necessary to have a phone line for each device you wished to use simultaneously. For example, one line each for the phone, fax, computer, and live video conference. Transferring a file to someone while talking on the phone, and seeing their live picture on a video screen would require several expensive phone lines.

Using multiplexing (a method of combining separate data signals together on one channel such that they may be decoded again at the destination), it is possible to combine many different digital data sources and have the information routed to the proper

destination. Since the line is digital, it is easier to keep the noise and interference out while combining these signals.

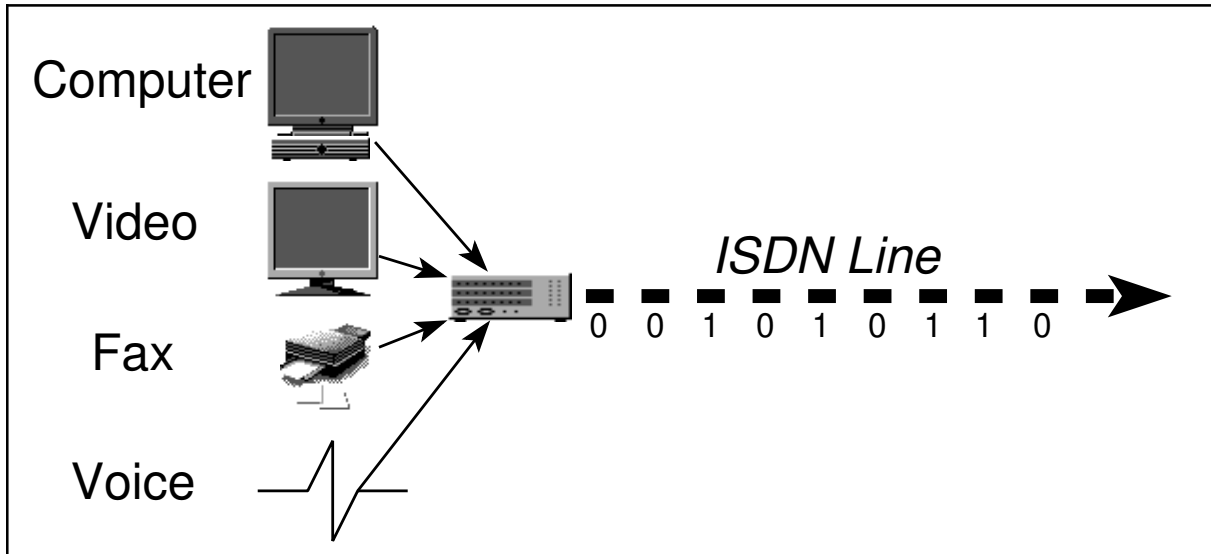

Figure 2 multiple devices connected to a single phone line

ISDN technically refers to a specific set of services provided through a limited and standardized set of interfaces. This architecture provides a number of integrated services currently provided by separate networks.

ISDN adds capabilities not found in standard phone service. The main feature is that instead of the phone company sending a ring voltage signal to ring the bell in your phone, it sends a digital package that tells who is calling (if available), what type of call it is (data/voice), and what number was dialed (if multiple numbers are used for a single line). ISDN phone equipment is then capable of making intelligent decisions on how to answer the call. In the case of a data call, baud rate and protocol information is also sent, making the connection instantaneous.

History of ISDN:

A standards movement was started by the International Telephone and Telegraph Consultative Committee (CCITT), a United Nations organization that coordinates international telecommunications. U.S. representation to this committee is

housed in the Department of State. The primary objective of CCITT is to standardize telecommunications globally. Original recommendations of ISDN were in CCITT Recommendation I.120(1984) which described some initial guidelines for implementing ISDN.¹

CCITT Recommendation I.120 (1984)

Principles:

- Support of voice and non-voice applications using a limited set of standardized facilities
- Support for switched and non-switched applications
- Reliance on 64-kbps connections
- Intelligence in the network
- Layered protocol architecture
- Variety of configurations

Evolution of ISDN:

- Evolution from existing telephone networks
- Transition of one or more decades
- Use of existing networks
- Interim user-network arrangements
- Connections at other than 64 kbps

Figure 3 CCITT ISDN Recommendations

Local phone networks, especially the regional Bell operating companies, have long hailed the system, but they have been criticized in recent years for being slow to implement ISDN. One good reason for the delay is the fact that the two major switch-makers, Northern Telecom, and AT&T selected different ways to implement the CCITT standards. These standards didn't always interoperate. Dick Notebaert, president of Ameritech Services, compared this situation to that of earlier 19th century railroading. "People had different gauges, different tracks... nothing worked well."²

¹ Stallings, William. ISDN: An Introduction. Collier Macmillan Canada, Inc. 1989.

² Ibata, David. "New information highway to the future." Chicago Tribune. Pg. 17. November 17, 1992.

In early 1991, an industry-wide effort began to establish a specific implementation for ISDN in the U.S. Members of the industry agreed to create National ISDN 1 so service users would not have to know the brand of switch they are connected to in order to buy equipment and software compatible with it.

TRIP '92 and NISDN-1:

In November 1992, the Corporation for Open Systems International (COS) and the North American ISDN Users' Forum (NIUF) joined forces to create a trade show, called Transcontinental ISDN Project 1992 (TRIP '92) - the first multicarrier ISDN event in the U.S. This exposition, held in Reston, Virginia, featured exhibits of ISDN products and services as well as the "Golden Splice" event which marked the commencement of transcontinental ISDN service.³

The main purpose of TRIP '92 was for telephone companies and vendors to prove that standardized ISDN service is available, and that there are applications to support it. It was also the true test of the NISDN-1 agreement to implement specific existing standards to ensure interoperability among carriers. Many vendors showed their products operating in situations such as videoconferencing.

NISDN-1 was created to address 3 major areas:⁴

- standardizing equipment and services
- standardizing telephone company procedures for operation
- standardizing communication among central offices

However, there still might be problems agreeing on this standard. In fact, many of the states west of the Mississippi River will not be able to get NISDN-1 specifications. Both Southwestern Bell Corp. and U.S. West Inc. said that they do not plan to deploy NISDN-1 software in their central office switches. They claim that this will cause incompatibilities with their

³ Johnson, Johna T. "ISDN Goes Nationwide, but Will Users Want It?" Data Communications. November 1992.

⁴ "National ISDN Network Launches New Era in Compatibility." Communications Daily. November 17, 1992.

existing ISDN networks. This creates problems for many large corporations in the U.S. who wish to connect their regional offices with ISDN technology.⁵

Specifics of ISDN:

With ISDN, voice and data are carried by bearer channels (B channel) occupying a bandwidth of 64 kbps each. A delta channel (D channel) handles signalling at 16 kbps or 64 kbps. H channels are provided for user information at higher bit rates.

There are three types of ISDN service: Basic Rate ISDN (BRI), Primary Rate ISDN (PRI), and Broadband ISDN (B-ISDN).

BRI: consists of two 64 kbps B channels and one 16 kbps D channel for a total of 144 kbps. The basic service is intended to meet the needs of most individual users. NISDN-1 focused primarily on making basic services deployed immediately.

PRI: intended for users with greater capacity requirements. Typically the channel structure is 23 B channels plus one 64 kbps D channel for a total of 1.544 Mbps. H channels can also be implemented: H0=384 kbps, H11=1536 kbps, H12=1920 kbps. NISDN-2 will address this protocol in depth during 1993.

B-ISDN: still in development and will support as much as 150 Mbps, but will be dependent on a complete optical fiber network. This could be a medium for future high definition television (HDTV) projects.

To access the BRI service, it is necessary for the customer to subscribe to an ISDN phone line. Residential customers will also need to use a device called a Network Terminator 1 (NT1). The NT1 performs the multiplexing and converts the 2-wire teleco line to the 4 wire ISDN signal.

⁵ Sweeney, Terry. "Two Bells Frustrate National ISDN Effort." Communications Week. November 23, 1992.

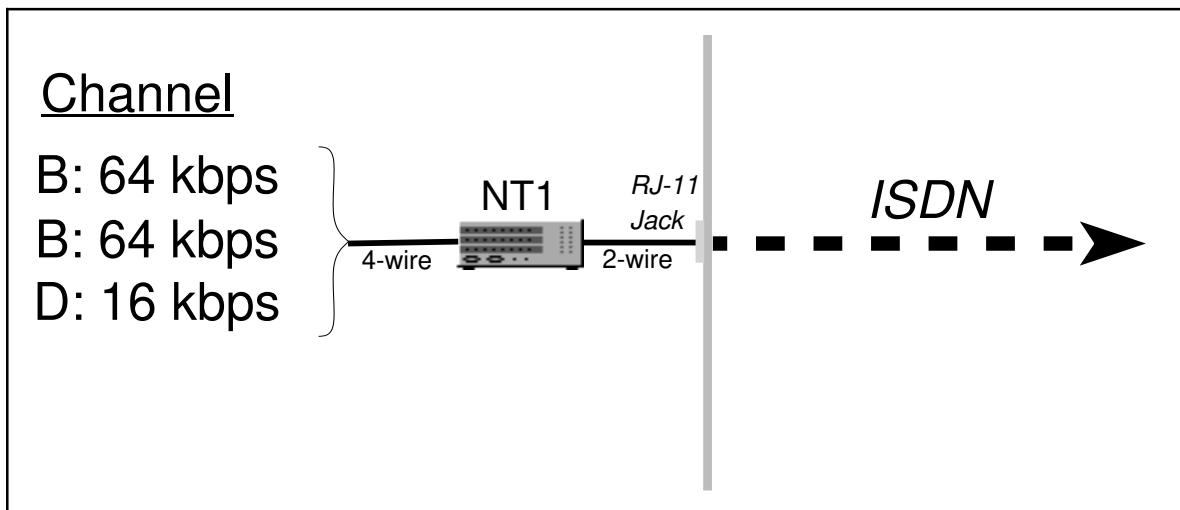

Figure 4 ISDN Basic Rate Interface

Many business customers have phone systems that are already digital. In this case, connecting to ISDN lines may or may not require additional hardware, depending on the system.

Many computer workstations are now being shipped with ISDN capabilities. These units connect directly to the NT1, and will integrate voice/data communications through the system software. But most computers require a Terminal Adapter (TA). This unit converts ISDN to the serial (RS-232) interface on most computers. But serial connections are usually limited to 19.2 Kbps, therefore the TA does not utilize the entire ISDN bandwidth.

Pricing & Availability:

More than 56% (115 million lines) of the regional Bell operating companies will have ISDN network access by late 1994.⁶ In Chicago, Ameritech officials say that 37% of the market, 1.2 million lines, will be ISDN by year-end 1992, and the entire metropolitan area of 4.5 million lines, by April 1993. Most of the 5 state Ameritech service region and major U.S. cities should be wired for ISDN by 1994.

Bellcore has set up a national ISDN information clearing house hotline at 800-992-4736 for information about ISDN availability.

⁶ "One Service for All." Computerworld. November 9, 1992.

Many companies are using ISDN where service is not yet available. This is possible by using other digital communications methods at the local level. A common method is to use a T1 line, or a fractional T1 line to connect the computing facility to a switch that does provide ISDN access. A T1 line multiplexes twenty-four 64 kbps channels together over a single line. A fractional T1 line is simply a chosen portion of the full T1 circuit.

Pricing still seems to be the least standardized part of ISDN. Installation charges generally run from \$200-\$400 for BRI service. Monthly charges are often in the \$15-\$45 range, plus usage charges. NT1 prices are \$200-\$300, and TAs are \$600-\$1200. Eventually, pricing is expected to be only slightly more than standard analog service.

Other digital services:

Switched 56: Unlike ISDN, this service is already offered by most carriers. It creates a virtual network over existing public phone lines with a 56 Kbps data rate. This service is cheap, but slow; therefore, it is ideal for intermittent data swapping between WANs.

SMDS (Switched Multi-megabit Data Services): Using a connectionless networking plan, each SMDS packet has its own address and does not require a virtual circuit. Proposed speeds are from 1.5 Mbps to 45 Mbps using a fixed-length packet of 53 KB. Many regional carriers are beginning to offer this service for local traffic.

ATM (Asynchronous Transfer Mode): Using the same 53 KB packets as SMDS, ATM uses virtual circuits to transfer data at speeds of 34 Mbps to multiple gigabits per second. The CCITT has decided on ATM as the transport standard for broadband ISDN when it becomes available. ATM is expected to be fully supported by the phone networks in 1995 or 1996.

Applications of ISDN:

Businesses have the potential to be the biggest winners in the future of ISDN services. It will be cost effective for companies to replace numerous existing analog lines with fewer ISDN lines

that can handle multiple applications simultaneously. But for the average residential user, there are also many benefits.

One of the most talked about ISDN applications is videoconferencing. Previously, systems cost well over \$100,000. Now the concept of personal, desktop videoconferencing is available using common personal computers and workstations. One channel is used for voice, and the other channel is used for the display of moving video pictures. The price for videoconferencing is dropping so quickly, that it is expected to be affordable to most businesses by late 1993.

Along similar lines, is a shared electronic chalk board. Users can talk in a conference arrangement and also illustrate written ideas to remote locations. Slide presentations could also be given in this manner.

Everyone appreciates the simple fact that is it possible to have the single phone jack do more than one task. The modem no longer needs to tie up the phone line. It is even possible to troubleshoot computers remotely by simultaneously talking to the computer operator and logging into that system remotely with the same ISDN line. But there are certainly far more exciting uses for this technology.

ISDN in education:

John Mayo, AT&T Bell Laboratories president stated that, "The new telecommunications technology that will impact education the most over the next five years, will be ISDN."⁷ The classroom will no longer have physical boundaries. Ideas of collaborative learning to gain outside expertise will be easier to implement over the existing telephone lines. Students will be able to communicate with schools across the city, or across the world.

The most exciting possibilities involve the video capabilities. Videoconferences can be used for instruction videos, or transmitting a school play. Students can see far away lands for the first time, or speak with a pen-pal halfway around the world.

⁷ "Appalachian State University, Southern Bell and AT&T Unveil and Demonstrate ISDN-driven Distance Network." Business Wire. October 6, 1992.

Exposing children to computers and networking at an early age seems to be the trend. ISDN allows the students' computers to access more resources and will teach them how to collaborate during their learning process. The current generation of children will certainly be expected to use the computer as a powerful tool much like the calculator and typewriter were used.

Telecommuting:

Telecommuting is a new term used to describe the modern way of working from home. There certainly is some motivation to avoid the daily commute if all of the work can be done from home. It will take managers a while to get used to this idea, and it certainly does require some self motivation. But with current technology, it is possible to have the remote computer respond as if there were expensive network cable running the whole way.

NeXT Computer, Inc. has started bundling the new release of their system software with tools for maintaining ISDN links. The software is perfect for telecommuting. It allows the home computer to connect to the office via an ISDN line and mount all file systems and network resources. Any work that could be done on the office computer can be performed on the home computer. Although NeXT doesn't have ISDN jacks on the system, Hayes Corporation has engineered a device that connects the Digital Signal Processor (DSP) port of the NeXT to an NT1. This allows the full use of ISDN bandwidth, whereas a terminal adapter connected to the serial port severely limits bandwidth.

Other systems can use popular protocols such as the Serial Line Interface Protocol (SLIP) or the Point-to-Point Protocol (PPP). The biggest advantage of using these protocols is actually being a node of a remote network. When you want access to resources not available locally, you can automatically connect. There is no longer the limitation of simply transferring files using a modem and terminal software. The computer will actually think it is connected to ethernet over ISDN.⁸

⁸ Landwehr, John T. "Taking your network home." NeXT Support Bulletin. Summer 1992.

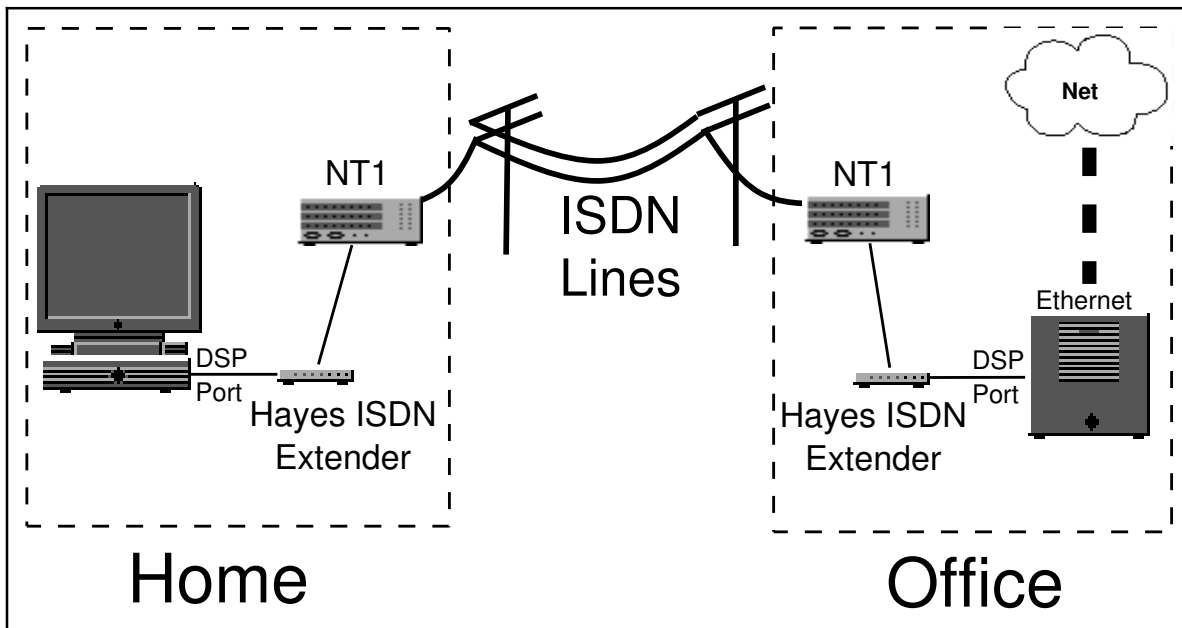

Figure 5 Telecommuting with a NeXT workstation

Possible problems with a digital phone network:

One of the first problems that comes to mind is concerning security. This is actually not a problem for the user, because digital transmissions are easily capable of being encrypted. In fact, an encryption key of 128 bits or more would prevent even the latest supercomputers from decoding the transmission.

The concern comes from the National Security Agency. They are worried about ISDN making wiretapping more difficult than it has been in the past. The agency has therefore given guidance to the computer industry to secure a back door into encrypted messages. They are also proposing new legislation to the FCC that would make all digital transmissions capable of being monitored by electronic surveillance.

The director of the FBI, William S. Sessions, is quoted as saying, "Terrorists, violent criminals, kidnapers, drug cartels and other criminal organizations will be able to carry out their illegal activities using the telecommunications system without detection."⁹

Finally, an example of the socio-political implications of ISDN has been summed up by Leonard R. Sussman, who predicted that technology and globally linked networks would result in the breakdown of censorious and suppressive political systems, meaning

⁹ "FBI Fear Phone Advances Will Hamper Wiretapping." LA Times, March 7, 1992.

that governments would have a difficult time hiding information from their people because of the rapid methods of transferring information at a global level.¹⁰

The future:

Computers are rapidly becoming connected together to help people that want to communicate with each other, regardless of location. The trend is definitely toward a digital world. Compact Disc players, telephones, computers, and televisions are all beginning to use digital technology.

The problem with ISDN hasn't been the technology, it's the politics. The reason ISDN was so slow to catch on was that the different telephone companies' equipment didn't work together. Until recently, it has not been possible to make an ISDN call from one telephone service area to another. As a result, users have been isolated from each other. With the advent of the National ISDN-1 network, standardized ISDN will become available over both local and long-distance telephone networks. When NISDN-2 kicks in by late 1993, it will add PRI services capable of 1.5 Mbps transmissions.

Pricing and local availability are now the key issues. In some areas, making an ISDN call is the same price as an analog call. But other carriers are making ISDN prohibitively expensive. While most metropolitan areas will be ISDN capable in several months, widespread residential use will not come as quickly.

Settling these political issues will affect ISDN's success in the U.S. Many claim that competing technologies are already far ahead of ISDN, but they are still facing many standardization and availability issues that ISDN has already begun conquering.

NISDN-1 is only the beginning. It is the first step in expanding the nation's phone network by making it digital. Next, it will be a matter of making those zeros and ones travel quicker as we see and hear information from all over the world, instantaneously.

¹⁰ Sussman, Leonard R. Power, The Press, & The Technology of Freedom, The Coming Age of ISDN. Freedom House. 1989.